

Pressure switches Temperature switches F Series

Characteristics*

- > Gauge, absolute and differential pressure control
- > Temperature control direct bulb or through capillary
- > Electrical contact or pneumatic signal output
- >  Available for installation in hazardous areas (ATEX)
 - . explosion-proof housing/contact
 - . intrinsic safety
 - . increased safety
 - . protection by constructional safety

- > Industrial and compact series
- > Low vibrations sensibility
- > SIL2 capability 
- > Harsh environment versions available on request
- > Made in France

* according to models

C O N T E N T S

Working principle	page 1
General information	page 2
Code numbers	page 3
Microswitches available with current rating	page 3
Pressure switches : ranges and dead bands	page 4
Differential pressure switches : ranges and dead bands	page 5
Temperature switches : ranges and dead bands	page 6
Temperature switches accessories	page 7
Dimensions and weight	page 8
Drawings	page 9

QUALITY NOTIFICATION LCIE 02 ATEX Q8023
FRENCH ELECTRICITY BOARD APPROVED
FRENCH RAILWAYS CERTIFIED
FRENCH NAVY CERTIFIED
NATO CODE F 3363
Czech FTZU and South Korea KISKO
GOST-R CERTIFICATE (Russian Federation)

A CERTIFIED RANGE OF PRODUCTS



ATEX 94/9 CE

PRESSURE and TEMPERATURE SWITCHES of the "F" Series from GEORGIN offer a wide range of products to suit most severe industrial applications where a high degree of accurate reliability is required.

Starting from the basic model FP4P, numerous sensing elements, microswitches, additional features or special treatments make the F Series suitable for:

- Power generation.
- Diesel engines, pumps and compressors.
- Oil fields, off-shores, pipe-lines and refineries.
- Trade or navy ship building.
- Petrochemical and chemical industries.
- Steam, burners and furnaces.
- Natural gas or LPG storage and transportation.
- Glass and metal industries.
- Compressed gas or high pressure fluids.
- Fail safe break control for railway engines.
- Hydraulic, steam and gas turbines.

Many other applications such as breweries, milk, surgical gas, fire protection, tyres air and water treatment, sugar and paper mills... can be obtained on request together with our national or international reference list.

OTHER PRODUCTS and SERVICES

GEORGIN offers as well a large range of intrinsically safe electronic devices (relays, converters, power supplies, indicators).

GEORGIN is certified (Nr 11 920 903 792) to give lectures concerning all fields of its activity.



• **FRANCE (Headquarters) :**
REGULATEURS GEORGIN
14-16, rue Pierre Sépard 92320 CHATILLON
Tel.: (+33) 1 46 12 60 00
Fax: (+33) 1 47 35 93 98
E-mail : regulateurs@georgin.com
www.georgin.com

• **BELGIQUE :**
REGULATEURS GEORGIN
Temselaan 5 - 1^{er} étage - 1853 STROMBEEK-BEVER
Tel. : 2 735 5475
Fax : 2 735 1679
E-mail : info@georgin.be

Smooth articulation pressure and temperature switches for industrial use where high resistance to vibrations is required

MODELS:	PRESSURE (absolute)	0.05 Bar	to	6 Bar
	PRESSURE (gauge)	- 1 Bar	to	800 Bar
	DIFFERENTIAL PRESSURE	0.02 Bar	to	100 Bar
	TEMPERATURE	- 90 °C	to	380 °C

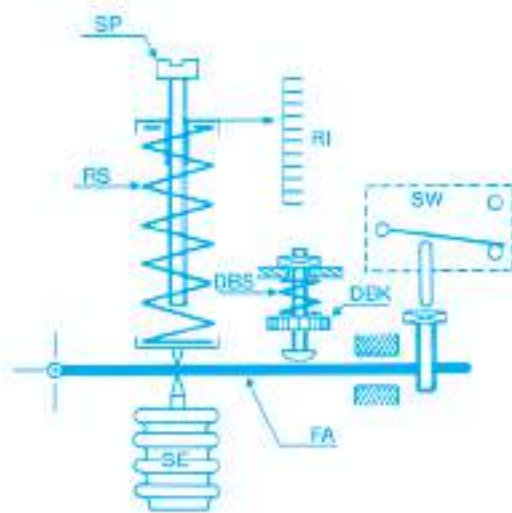

SP	Set point (range adjustment screw)
RS	Range spring
RI	Range index
DBS	Dead band adjustment spring
DBK	Dead band adjustment knob
SE	Sensing element
FA	Flexible arm
SW	Switch

Working principle: A ductile sensing element (bellows, diaphragm, bourdon tube) actuates a microswitch.

The set point is obtained by calibrating the range spring mounted in the force balance position.

The dead band adjustment spring allows the proper differential value of the contact to be increased.

The force balance principle allows the dead band setting value to remain nearly constant independently from set point adjustment.

Note: Continuous development of our products may necessitate changes without notice. Please check with our Sales office prior to ordering.



Georgin offers a wide range of “SIL capability” products and assists his customers in securing their industrial sites to meet the requirements of a safety instrumented function in compliance with the Machinery Directive 2006/42/EC.

The reputation of reliability of F-Series Pressure and temperature switches was quantified by leading an operational feedback analysis.

All our approved SIL products allow SIL2 capacity without redundancy or external monitoring in accordance with the architecture of 1oo1 Markov.

For more informations, refer to our certificate.

Construction

According to EN 60529 (IEC 529).

IP 66 (68 as option) or IP 56 for relative diaphragm pressure switches type FML, FMS, and FMT.

Epoxy coated die-cast aluminium housing and cover.

Polyester (FPP) or die-cast aluminium explosion-proof housing (RTPF) also available ( approved).

Cadmium plated or stainless steel screws and bolts on extra.

External set point setting. Factory sealed on request.

Graduated internal scale. (OPTION : cover with scale window-IP 66)

Sensing elements:

- Bronze or stainless steel bellows (316 L)
- Stainless steel bourdon tube (316 Ti)
- NBR (standard), FKM or EPDM diaphragms
- Copper or 316 Ti stainless steel temperature sensor.

According to type and range, diaphragm seals with or without capillary extension may be quoted against specification.

As option a breather is available to limit condensation.

Process connections: Brass or 316 L

- BSP connection according to NF E03-005-1 / EN ISO 228-1
- 1/2" BSPM as a standard - 1/4" BSPM for diaphragm operated except (D)FML
- NPT connection according to NF E 03-601
- Other process connections on request

Mounting:

- **Panel** 5 mm threaded holes as standard
- **Wall** cadmium plated steel fixing clips (2 off). Any special on request.

Electrical switching and features

1 or 2 change over switches (SPDT).

Dry, nitrogen sealed, explosion-proof or gold plated types according to application.

Electrical entry:

- 1 or 2, 3 wire screw terminal (1.5 mm² max. each)
- 1 or 2 packing gland (ISO M16) or ISO 4400 connector
- Approved screw terminal and packing gland for use in the **EEEx ed** version
- External earthing screw connection (optional). Other connection arrangements on request.

Pneumatic switching

Normally Open (NO) or Normally Closed (NC) contact

Fluid supply : 1.5 to 8 bar (spool design) or 0 to 10 bar (poppet design – no leakage)

Fluid usage (spool design) : 10 to 52 liters/hour according to piloting pressure

Piloting fluid : dry fluid (max filtration 5 µm) - air, nitrogen or any compatible fluid meeting standard ISO-VG 10

Cell connection : 1/8" BSPF (others on request)

Operating temperature : -10 to +60°C

Certifications

All equipment designed in accordance with ATEX directives 94/9 EC.

- **Intrinsic Safety Ex ia/Ex iaD**

- **Explosionproof solution Ex d/Ex td**

- **Increased safety Ex de/Ex td**

- **Protection by constructional safety « c »**



LCIE 01 ATEX 6008X

LCIE 01 ATEX 6071X

LCIE 02 ATEX 6161X

10AR046MN (pneumatic switches for use in potentially explosive atmospheres ATEX)

Applications

Every process fluids suitable with selected measuring element and process environment (see recommendations).

Temperature limits (material)

Typical characteristics	:	
Bronze bellows	:	- 20 to + 60°C
St.St. bellows	:	- 20 to +150°C
Bourdon tube	:	- 20 to +150°C
NBR diaphragm (Bunan® type)	:	- 20 to +100°C
FKM diaphragm (Viton® type)	:	0 to +150°C
EPDM diaphragm	:	- 40 to +120°C

Temperature bulbs according to specified range.

Working temperature (housing)

- 20 to +70 °C (except FB (A) and FC-ranges B, C and G: maxi 55 °C).

Storage temperature

- 40 to +70 °C (except temperature switches ranges B, C and G: maxi 55 °C).

Repeatability

±1 % of full scale in constant cycle and temperature.

Recommendations

- Live, corrosive or crystallisable fluids will necessitate the use of well defined diaphragm seal. Process conditions to be clearly specified when ordering.
- Use upstream dampener against foreseeable process quick changes (on/off values, piston pumps for example).
- Location must be chosen so that temperature of internals will never exceed maximum specified limits for complete assembly. Biggest care must be taken against radiations from heater sources.
- It is strongly recommended to protect outdoor mounted instrument against excessive sunshine and nocturnal condensations. Special attention to be paid when installing in coastal areas or damp atmospheres. Air exhausts, filters and drains are available as accessories.
- High degree of protection against vibrations does not exclude choosing the most stable location. In some cases excessive level of vibrations may necessitate the use of flexible piping connection together with silent-blocks mounting devices.
- Upstream condensing pot or similar piping devices will be provided for steam pressure measurement.

CODE

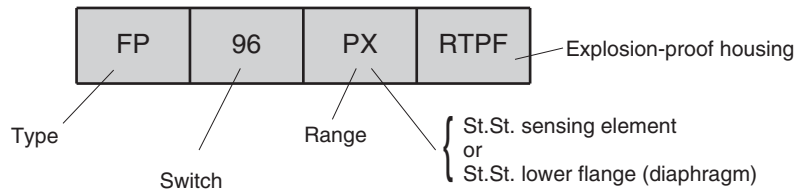

That is to say for this example: A 1 to 10 bar pressure switch in explosion-proof housing, with stainless steel bellows and nitrogen sealed contacts.

Available models:

Pressure switches:	Absolute (bellows)	FV
	Bellows	FP / FPH
	Diaphragm	FML / FMS / FPA - FPAS / FMT
	Bourdon tube	FPL
	Differential (bellows)	FD / FDH
	Differential (diaphragm)	DFMS / DFML / DFMT
Temperature switches:	Straight bulb	FB / FBA (ambient)
	Bulb and capillary	FC

Electrical switches

		Fixed dead band	Adjustable dead band
1 Change over (SPDT)	Standard	4, 4 D	6, 6 D
	Tight dead band	10, 10 D, 16, 16 D	–
2 SPDT (acting together)	Nitrogen sealed	–	96
	Expl. proof	–	62, 62 C, 62 D
	Exp. pr. (tight dead band)	60, 60 C, 60 D	–
		Adjustable lagging	
2 SPDT (two steps)	Standard	–	34, 34 D
	Nitrogen sealed	–	106
	Expl. proof	160 C	162 C
	Exp. pr. (tight dead band)		–
		Adjustable lagging	
2 SPDT (two steps)	Standard	54, 54 D	
	Nitrogen sealed	116	
	Expl. proof	172 C	
	Exp. pr. (tight dead band)	170 C	

[C] means Ex d explosion-proof switch with 1 m cable length for use with certified junction terminal (3 or 5 meters length on extra).

[D] means gold plated contacts for intrinsically safe applications. Also suitable for low voltage signals.

Associated GeorGIN I.S. approved relay interfaces also available for 19" rack, plug-in modules or DIN rail mounting.

Note: 4, 6, 34 and 54 are tropicalised contacts as standard.

CONTACT RATING (resistive loads)

Contact Nr		AC		DC	
Standard	4, 6, 34, 54	10 A	240 V	0.5 A	110 V
Tight dead band	10	5 A	240 V	0.5 A	130 V
Very tight dead band	16	2 A	240 V	1 A	130 V
⊗ Nitrogen sealed	96, 106, 116	2.5 A	240 V	1 A	130 V
⊗ Gold plated	4 D, 6 D, 34 D, 54 D	–	–	1 mA / 100 mA	4 V / 30 V
⊗ Tight gold plated	10 D	–	–	50 mA	30 V
⊗ Tight gold plated	16 D	–	–	10 mA / 100 mA	6 V / 24 V
⊗ Expl. proof	62, 62 C, 162 C, 172 C	5 A	240 V	0.4 A	250 V
⊗ Tight expl. proof	60, 60 C, 160 C, 170 C	7 A	240 V	0.25 A	250 V

PRESSURE SWITCHES FOR ABSOLUTE PRESSURE (bellows actuated)

Type	Range	1 SPDT 1°									2 1° 1°	Max. dead band ≥	P max.
		Fixed dead band ≤				Adjustable dead band ≤							
	4	10	16	60	6	62	96	34	106	bar	abs. bar		
FV . H (X)	0.05 to 1	50	12	5	22	50	65	55	55	85	0.25	3	
FV . N (X)	0 to 2	115	30	10	45	115	160	120	120	170	0.5	8 (9)*	
FV . M (X)	0.2 to 6	255	60	25	120	255	360	300	280	410	1	14	

* 8 bar ABS for pressure switches RTPF type

PRESSURE SWITCHES (diaphragm actuated)

Type	Range	1 SPDT 1°																2 1° 1°	Max. dead band ≥	P max.									
		Fixed dead band ≤								Adjustable dead band ≤																			
	4	10	16	60	6	62	96	34	106	mbar																bar			
FML . B (X)	0 to 20	L	H	L	H	L	H	L	H	L	H	L	H	L	H	L	H	L	H	L	H	L	H	L	H	0.02	0.3		
FML . C (X)	0 to 40	2.3	3	0.8	1.1	0.4	0.5	1.6	2.2	2.3	3	4	5.5	3	4												0.02	0.3	
FML . D (X)	-50 to 10	2.6	3.4	0.9	1.2	0.5	0.6	1.8	2.4	2.6	3.4	4.5	6	3.5	4.5												0.02	0.3	
FML . H (X)	0 to 80	3.5	4.5	1.1	1.4	0.6	0.9	2.2	2.8	3.5	4.5	5.5	7	4.5	5.5												0.02	0.3	
FMS . J (X)	0 to 500	3	4	1	1.3	0.5	0.7	2	2.6	3	4	5	6.5	4	5												0.2	80	
FMS . M (X)	0 to 1000	45	55	10	12	4	5	20	24	45	55	60	75	50	70	50	60	80	95								0.2	80	
FMT . F (X)	10 to 250	50	60	11	15	5	6	22	28	50	60	65	85	55	75	55	70	85	105								0.1	200	
FMT . G (X)	10 to 500	23	28	5	6	2	2.5	10	12	23	28	30	40	25	35	25	30	40	50								0.1	200	
	bar	PULSED PRESSURE OR OVERRANGE PROTECTION																											
FPA . K (X)	-1 to 5	23	28	5	6	2	2.5	10	12	23	28	30	40	25	35	25	30	40	50								0.1	200	
FPA . P (X)	▲0.5 to 10	25	30	5.5	7.5	2.5	3	11	14	25	30	35	45	30	40	30	35	45	55								0.1	200	
FPA . Q (X)	2.5 to 25	140	210	30	45	16	24	70	105	140	210	160	240	170	260	170	250	270	400								1	80*	
FPA . R (X)	5 to 50	240	420	50	75	30	45	120	185	240	420	280	450	400	500	280	450	500	750								2	80*	
		600	850	120	175	60	90	300	400	600	850	650	950	750	1050	650	950	1100	1600									5	80*
		1400	2100	300	450	140	210	600	900	1400	2100	1600	2400	1700	2500	1550	2300	2300	3500									10	80*

L and H are the lowest possible dead band values for set points in Lowest or Highest part of the range.

* Available with 200 bar - Ref. FPAS (K, P, Q, R (X)).

▲ For switches range P (X) fitted with micro switches 96/106, range becomes : 1 to 10 bar.

PRESSURE SWITCHES (bellows actuated)

Type	Range	1 SPDT 1°									2 1° 1°	Max. dead band ≥	P max.					
		Fixed dead band ≤				Adjustable dead band ≤												
	4	10	16	60	6	62	96	34	106	mbar								
FP . A (X)	-1 to 0	35	7.5	4	17	35	45	45	40	70	0.25	1.5 (2)						
FP . F (X)	■ 0 to 0.25	18	4	3.2	14	18	27	35	24	60	0.25	1.5 (2)						
FP . G (X)	■ 0 to 0.5	20	5	3.3	15	20	30	37	26	62	0.25	1.5 (2)						
FP . M (X)	■ 0 to 1	25	5.5	3.5	15	25	35	40	30	65	0.25	1.5 (2)						
FP . L (X)	-1 to 1	70	15.5	7	35	70	95	85	75	130	0.5	7 (8)*						
FP . N (X)	◆ 0.1 to 2	50	11.5	6	30	50	70	70	65	125	0.5	7 (8)*						
FP . K (X)	-1 to 5	165	40	20	85	165	240	215	190	350	1	13 (15)						
FP . P (X)	▲ 0.5 to 10	240	55	30	140	240	350	360	285	600	2	13 (15)						
FP . Q (X)	2.5 to 25	600	140	70	305	600	850	800	680	1300	5	30						
FP . RX	5 to 50	1400	320	150	700	1400	2000	1800	1600	2800	10	80						
FP . SX	10 to 125	4500	1000	400	2000	4500	6000	5000	4800	7500	20	250						
FPH . G (X)	● 0 to 0.5	40	9	6	26	40	60	70	55	120	0.5	7 (8)*						
FPH . K (X)	-0.5 to 6	450	140	40	190	450	650	500	500	650	1.5	30						
FPH . P (X)	1 to 10	500	150	40	200	500	700	550	550	700	1.5	30						

▲ For switches fitted with micro switches 96/106/116, range becomes : low of ranges is 1 bar.

■ For switches fitted with micro switches 96/106/116, range becomes : low of ranges is 0.05 bar.

◆ For switches fitted with micro switches 96/106/116, range becomes : low of ranges is 0.2 bar.

● For switches fitted with micro switches 96/106/116, range becomes and bronze bellows low of range is 0.05 bar.

* 7 bar for pressure switches RTPF type

PRESSURE SWITCHES FOR HIGH PRESSURE (bourdon tube actuated)

Type	Range	1 SPDT ?°								2 $\text{?}^\circ \text{?}^\circ$		Max. dead band \geq	P max.
		Fixed dead band \leq				Adjustable dead band \leq							
		4	10	16	60	6	62	96	34	106	bar		
bar		bar										bar	
FPL . TX	10 to 200	16	4	1.6	7.5	16	22	19	18	30	100	300	
FPL . VX	25 to 400	32	8	3.2	15.5	32	46	40	38	60	200	600	
FPL . YX	30 to 800	38	9	3.5	17	38	54	45	42	65	200	1000	

DIFFERENTIAL PRESSURE SWITCHES (diaphragm actuated)

Type	Range ΔP	1 SPDT ?°																2 $\text{?}^\circ \text{?}^\circ$		Max. dead band \geq	Min/max. static P.
		Fixed dead band \leq								Adjustable dead band \leq											
		4	10	16	60	6	62	96	34	106	bar		bar								
mbar		mbar																bar			
DFML . B (X)	0 to 20	L	H	L	H	L	H	L	H	L	H	L	H	L	H	L	H	L	H	0.02	- 0.3/0.3
DFML . C (X)	0 to 40	2.6	3.4	0.9	1.2	0.5	0.6	1.8	2.4	2.6	3.4	4.5	6	3.5	4.5			-	-	0.02	- 0.3/0.3
DFML . H (X)	0 to 80	3	3.8	1	1.3	0.6	0.7	2	2.6	3	3.8	5	7	4	5			-	-	0.02	- 0.3/0.3
DFMS . J (X)	50 to 500	3.5	4.5	1.1	1.4	0.6	0.8	2.2	2.8	3.5	4.5	5.5	7.5	4.5	5.5					0.02	- 0.3/0.3
DFMS . M (X)	50 to 1000	65	80	15	18	5.5	6.5	28	32	65	80	90	110	70	85	70	85	95	115	0.2	Patm./80
DFMT . F (X)	10 to 250	70	90	18	22	6	7.5	30	36	70	90	95	125	75	95	75	95	100	130	0.2	Patm./80
DFMT . G (X)	10 to 500	30	40	7.5	9	3	3.5	14	16	30	40	45	55	35	45	35	45	50	60	0.1	Patm./200
		35	45	9	11	3	4	15	18	35	45	50	65	40	50	40	50	55	65	0.1	Patm./200

DIFFERENTIAL PRESSURE SWITCHES (bellows actuated)

Type	Range ΔP	1 SPDT ?°										2 $\text{?}^\circ \text{?}^\circ$		Max. dead band \geq	Min/max. static P.
		Fixed dead band \leq					Adjustable dead band \leq								
		4	10	16	60	6	62	96	34	106	bar		bar		
bar		mbar										bar			
FD . H (X)	0.05 to 1	50	12	5	25	50	70	60	55	85	0.25	- 1 / 1.5 (2)			
FD . N (X)	0.1 to 2	115	30	10	45	115	160	120	120	170	0.5	0 / 7 (8)*			
FD . M (X)	0.2 to 5	285	65	25	120	285	380	330	300	450	1	0.5 / 13 (15)			
FD . P (X)	0.5 to 10	350	85	35	165	350	500	430	400	700	2	0.5 / 13 (15)			
FD . Q (X)	1 to 20	950	240	85	420	950	1400	1150	1100	1600	5	2.5 / 30			
FD . RX	2.5 to 50	2300	550	190	950	2300	3000	2600	2500	3500	10	5 / 80			
FD . SX	5 to 100	7000	1800	550	2700	7000	10000	7000	8000	10000	20	10 / 250			
FDH . G (X)	0.05 to 0.5	100	24	9	44	100	140	110	110	150	0.5	Patm. / 7 (8)*			
FDH . N (X)	0.4 to 2	750	180	50	280	750	1050	750	850	950	1.5	2.5 / 30			
FDH . P (X)	0.5 to 10	850	200	80	400	850	1200	950	1000	1500	5	2.5 / 30			
FDH . QX	1 to 20	2200	510	186	940	2200	3000	2400	2300	3400	10	5 / 80			

* 7 bar for pressure switches RTPF type

Dead band values are those recorded with:

- LP to atmosphere for range \leq 1 Bar
- 5 B stat. P for: $10 \geq$ range > 1 Bar
- 15 B stat. P for: $50 \geq$ range > 10 Bar
- 30 B stat. P for: range > 50 Bar

FML and DFML must be mounted in horizontal position. They may have a minor leakage on upper part of the diaphragm flange.

Note: Minimum static pressure must always be higher than Lower pressure + ΔP + dead band according to selected switch code. Both measuring chambers will accept the maximum specified static pressure.

L and H are the lowest possible dead band values for set points in Lowest or Highest part of the range. Dead band values are given for a pressure variation of 5% of the full range per minute. Dead band must be multiplied by 1.5 for explosion-proof housing (RTPF).

STRAIGHT BULB TEMPERATURE SWITCHES (vapour pressure)

Bulb Ø 14x120 mm

Type	Range	1 SPDT \varnothing°																2 $\varnothing^\circ \varnothing^\circ$				Max. dead band \geq	T max.			
		Fixed dead band \leq								Adjustable dead band \leq																
		4	10	16	60	6	62	96	34	106																
°C		°C																°C								
FB . G	-20 to 45	L	H	L	H	L	H	L	H	L	H	L	H	L	H	L	H	L	H	L	H	L	H	20	7	55
FB . P	20 to 95	4.5	1.2	1	0.3	0.8	0.2	3	0.7	4.5	1.2	6.5	1.6	7	2	6	1.5	12	3	25	8	105				
FB . R	45 to 120	5	1.2	1.2	0.3	0.8	0.2	3	0.7	5	1.2	7	1.6	7.5	2	6.5	1.5	13	3	25	8	135				
SPECIAL SERIES FOR AMBIENT TEMPERATURE (Bulb 14x40 mm)																										
FBA . GX	-20 to 45	4	1	1	0.2	0.6	1	2.5	0.6	4	1	5.5	1.4	6	1.5	5	1.5	10	2.5	20	7	55				
FBA . PX	20 to 70	4.5	1.8	1	0.5	0.8	0.3	3	1	4.5	1.8	6.5	2.5	7	2.8	6	2.2	12	4.5	25	10	70				

BULB AND CAPILLARY TEMPERATURE SWITCHES (vapour pressure)

Type	Range	1 SPDT \varnothing°																2 $\varnothing^\circ \varnothing^\circ$				Max. dead band \geq	T max. **			
		Fixed dead band \leq								Adjustable dead band \leq																
		4	10	16	60	6	62	96	34	106																
°C		°C																°C								
FC . B (X)	-90 to -30	L	H	L	H	L	H	L	H	L	H	L	H	L	H	L	H	L	H	L	H	L	H	25	5	50
FC . C (X)	-50 to -10	7.5	1.8	1.8	0.5	0.7	0.2	3	0.8	7.5	1.8	9.5	2.5	8	2.2	8	2.2	10	2.5	20	5	55				
FC . G (X)	-20 to 45	4	1	1	0.2	0.6	0.1	2.5	0.6	4	1	5.5	1.4	6	1.5	5	1.5	10	2.5	20	7	55				
FC . P (X)	20 to 95	4.5	1.2	1	0.3	0.8	0.2	3	0.7	4.5	1.2	6.5	1.6	7	2.2	6	1.5	12	3	25	8	105				
FC . R (X)	45 to 120	5	1.2	1.2	0.3	0.8	0.2	3	0.7	5	1.2	7	1.6	7.5	2.2	6.5	1.5	13	3	25	8	135				
FC . R2 (X)	65 to 170	10	2	2	0.5	1.6	0.3	4	0.9	10	2	12	2.2	12.5	2.6	12	2.2	17	4	40	12	180				
FC . T (X)	115 to 210	4.5	1.5	1	0.4	0.8	0.3	3	1	4.5	1.5	6.5	2	7	2.5	6	2	12	4	25	8	225				
FC . V (X)	150 to 250	5.5	1.5	1.5	0.4	0.8	0.3	3.5	1	5.5	1.5	8	2	8.5	2.5	7	2	15	4	25	8	265				
FC . V2 (X)	180 to 300	11	2.8	2.5	0.6	1.8	0.4	5	1.2	11	2.8	12.5	3	13.5	3.5	12.5	3	20	5.5	45	15	320				
FC . WX*	270 to 380	9	2.4	2.1	0.6	1.2	0.3	5.5	1.4	9	2.4	13.5	3.5	14	3.8	11	3.1	20	5.8	35	12	400				

L and H are the lowest possible dead band values for set points in Lowest or Highest part of the range.

Dead band must be multiplied by 1.5 for explosion-proof housing (RTPF).

* Working temperature $> +6^\circ\text{C}$.

** On request, maximum temperature can be increased with special ranges.

Notes: Values as shown on tables are those recorded under optimum conditions and with a bulb fully immersed in an agitated bath.

Install the probe vertically (capillary output up) or up to 45° angle. Between 45° and 75° angle, please consider the operating and the ambient temperature. Up to 75° angle, on request.

BULB AND CAPILLARY DIMENSIONS

(Selection table according to ambient temperature)

AMB T. (°C)	-20 to 5	5 to 35	35 to 70	-20 to 5	5 to 35	35 to 70	-20 to 5	5 to 35	35 to 70	-20 to 5	5 to 35	35 to 70
BULB (mm)	Ø 9x L 120			Ø 10x L 150			Ø 14x L 150			Ø 14x L 236		
Type	Capillary length (meters) *											
FC . B (X)	2	2	2	2	2	2	2 to 6	2 to 6	2 to 6	2 to 6	2 to 6	2 to 6
FC . C (X)	-	-	2	-	-	-	2 to 6	2 to 6	2 to 6	2 to 16	2 to 16	2 to 16
FC . G (X)	2	2	2	-	-	-	2 to 6	2 to 6	2 to 6	2 to 16	2 to 16	2 to 16
FC . P (X)	2 to 6	2	2	2 to 20	-	-	2 to 20	2 to 6	2 to 6	2 to 20	2 to 16	2 to 16
FC . R (X)	2 to 6	2 to 6	2	2 to 20	2 to 20	-	2 to 20	2 to 20	2 to 6	2 to 20	2 to 20	2 to 16
FC . T (X)	2 to 6	2 to 6	2 to 6	2 to 20	2 to 20	2 to 20	2 to 20	2 to 20	2 to 20	2 to 20	2 to 20	2 to 20
FC . V (X)	2 to 6	2 to 6	2 to 6	2 to 20	2 to 20	2 to 20	2 to 20	2 to 20	2 to 20	2 to 20	2 to 20	2 to 20
FC . WX	2 to 6	2 to 6	2 to 6	2 to 20	2 to 20	2 to 20	2 to 20	2 to 20	2 to 20	2 to 20	2 to 20	2 to 20

* 2 meters as standard; other length on request. (4 or 6 m for bulb Ø 9 mm).

Note: Standard bulb: - St. Steel : Ø 14x 150 mm

- Copper : Ø 10x 150 mm (except for ranges around ambient temperature: Ø 14x 150 mm).

TEMPERATURE SWITCHES ACCESSORIES

Soldered pocket with compression gland and capillary

For bulb mm	A mm	B mm	C mm	D 6 sided	E Tapper	F mm	Reference	
							Brass	St.St.
9x 120	115	16	16	26	G 1/2	12	GC-41	GCX-41
10x 150	145	22	22	29	G 3/4	13 *	GC- 1	GCX- 1
10x 150	145	22	22	29	G 1/2	13 *	GC-11	GCX-11
14x 120**	105	22	22	29	G 3/4	17	GB-21	GBX-21
14x 150	145	22	22	29	G 3/4	17	GC-21	GCX-21
14x 120**	105	22	22	29	G 1/2	17	-	GBX-61
14x 150	145	22	22	29	G 1/2	17	-	GCX-61
14x 236	232	22	22	29	G 3/4	17	GC-25	GCX-25

* Ø 14 for Stainless Steel.
 ** For type FB.
 Other dimensions on request.

Add "B" to code GC for NPT threading, ie = GC (X) 41B.
 Barstock drilled thermowells also available according to customer specifications.



Compression gland and capillary (reference : PC (X))

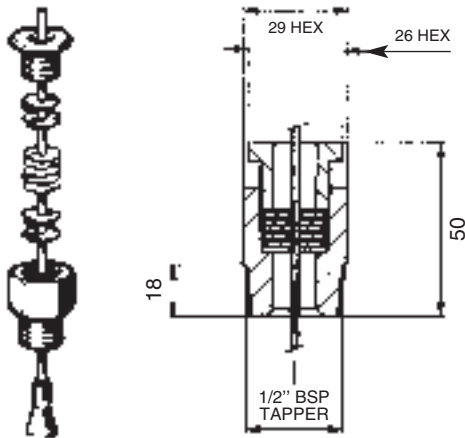

IMPORTANT

Time reaction of a bulb mounted in a pocket can strongly influence the measurement.

Such influence is mostly depending on thickness, type of material of the pocket and diameter of the bulb into the pocket.

It is advised to fill free space in the pocket with conductive liquid or paste whenever a high sensibility is requested.

Overfilling is dangerous for the bulb when screwing the pressure gland.

SENSING ELEMENTS (TEMPERATURE)

Capillary armour (option)

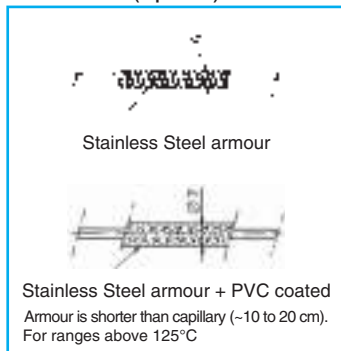

Dimensions in mm

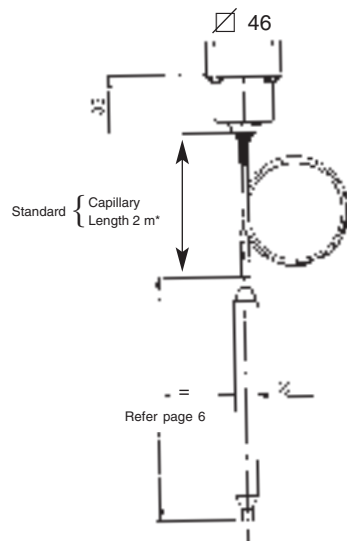

Type : FC

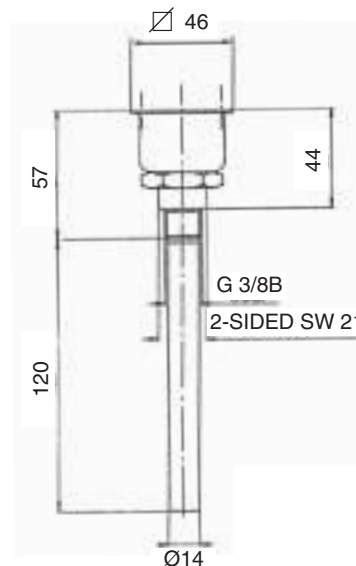

Type : FB

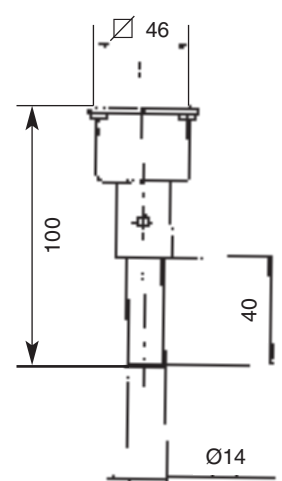

Type : FBA

APPROXIMATE DIMENSIONS AND WEIGHTS

TYPE	RANGES	STANDARD CASE		EXPLOSION-PROOF HOUSING	
		WEIGHT (kg)	H × w × d (mm)	WEIGHT (kg)	H × w × d (mm)
FML / DFML	All	2.6	212 × 220 × 220	3.6	272 × 265 × 220
FMS / DFMS	–	4.1	193 × 108 × 108	5.1	253 × 210 × 127
FMT / DFMT	–	8.5	212 × 220 × 220	9.5	272 × 265 × 220
FPA / FPAS	–	1.5	172 × 100 × 100	2.5	199 × 210 × 109
FP	A - F - G - L - M - N	1.5	210 × 110 × 81	2.5	237 × 210 × 109
FP	K - P - Q - R - S	1.2	183 × 100 × 81	2.2	237 × 210 × 109
FPH	G - N	1.5	210 × 110 × 81	2.5	237 × 210 × 109
FPH	K - P - Q	1.2	183 × 100 × 81	2.2	237 × 210 × 109
FPL	All	1.6	210 × 142 × 81	2.6	259 × 210 × 109
FV	–	2.3	225 × 188 × 81	3.3	269 × 210 × 109
FD	–	2.3	225 × 188 × 81	3.3	269 × 210 × 109
FDH	–	2.3	225 × 188 × 81	3.3	269 × 210 × 109
FBA	–	1.2	223 × 100 × 81	2.2	272 × 210 × 109
FB	–	1.3	293 × 100 × 81	2.3	342 × 210 × 109
FC (cap. 2 m)	–	≥ 1.6	According to capillary	≥ 2.6	According to capillary

HOUSINGS

REMINDER :
Instrument's mounting must follow recommended manner.
For this reason, pay attention to mounting instructions given in instruction manual or contact our technical staff.

Dimensions in mm

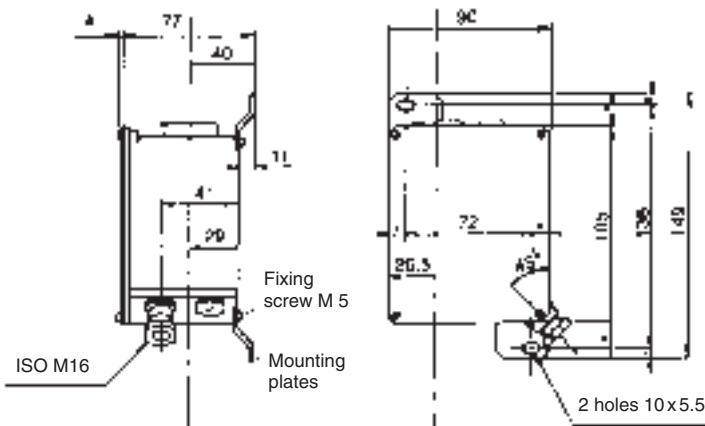

Standard case IP 66 - Type: **F**

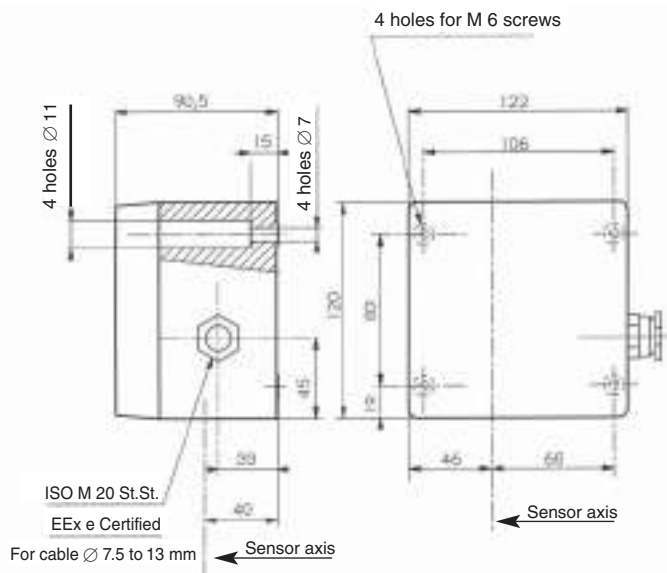

Polyester housing IP 65 - Type: **FPF**

Ex de / Ex tD (increased safety) - LCIE 02 ATEX 6161X

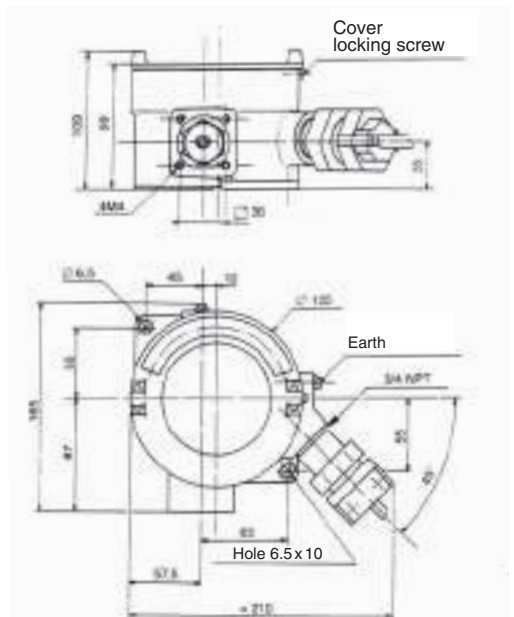

Explosion-proof housing IP 66 - Type: **RTPF**

Ex d / Ex tD - LCIE 01 ATEX 6071X

SENSING ELEMENTS (PRESSURE SWITCHES)

DIAPHRAGM

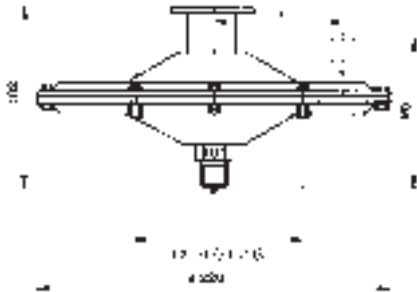

FML/DFML

BELLOWS

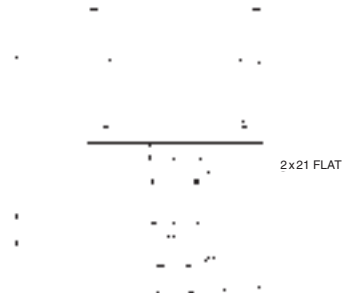

FP (A - F - G - L - M - N) - FPH.G (X)

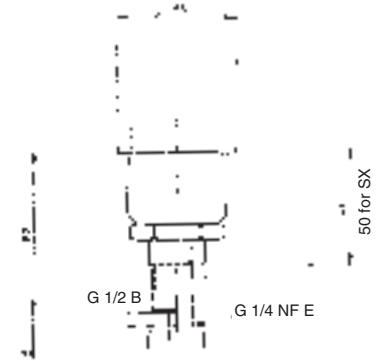

FP (K - P - Q - R - S) - FPH (except G (X))

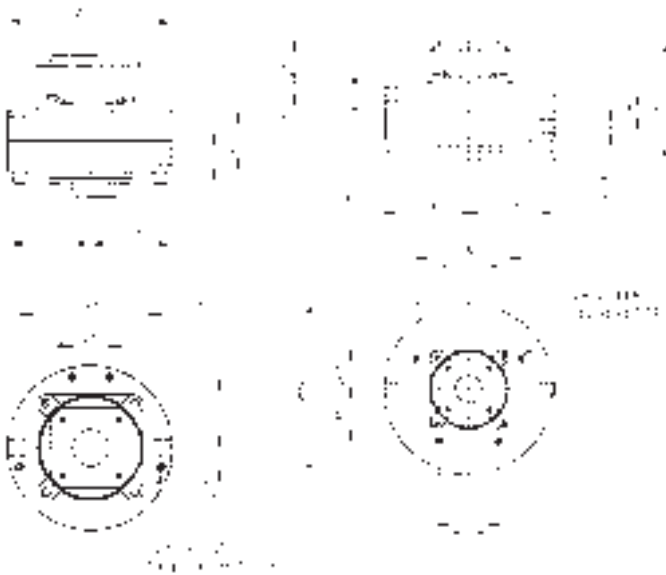

FMS / DFMS

FMT / DFMT

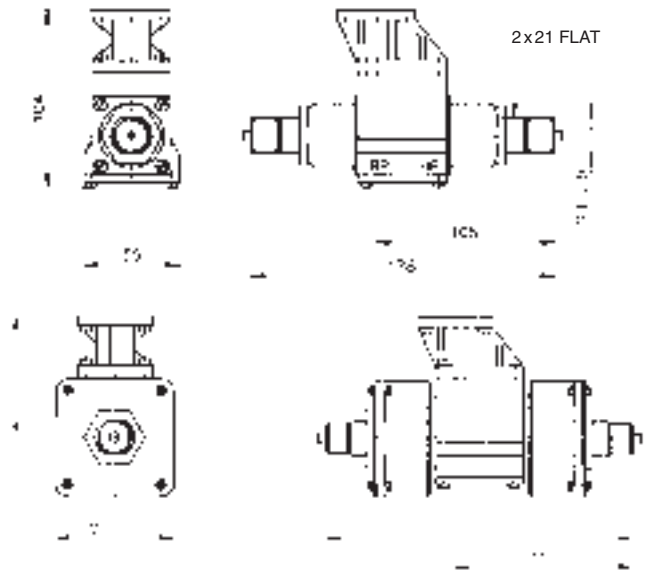

FD - FDH - FV

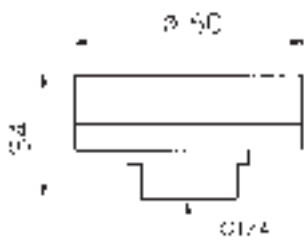

FPA / FPAS

MANOMETRIC TUBE

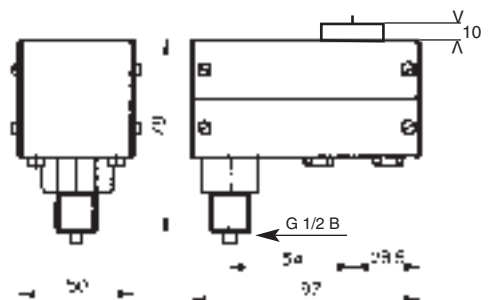

FPL

Dimensions in mm

ATEX CERTIFIED INSTRUMENT - INTRINSIC SAFETY (Ex ia)

Principle : gold plated switch for low current – must be connected to intrinsically safe certified equipment

Housing : standard

According to IP housing, markings, using zones and equipment categories are the following :

EC examination type Examination type	LCIE 01 ATEX 6008X	LCIE 01 ATEX 6008X LCIE 08 ATEX 6057X (voluntary attestation)
Housing protection	IP66 - IP 68	IP56
Marking	CE 0081 Ex II 1GD Exia IIC T6 - Ex iaD 20	CE 0081 Ex II 1G/3D Exia IIC T6 - Ex iaD 22
for ATEX zones	0 / 1 / 2 for gas of groups IIA, IIB, IIC 20 / 21 / 22 for dusts	0 / 1 / 2 for gas of groups IIA, IIB, IIC 22 for non-conductive dusts
Equipment category	1GD	1G/3D (non-conductive dusts)
Max. surface temperature	80°C	

ATEX CERTIFIED INSTRUMENT - INCREASED SAFETY (Ex de)

Principle : explosion proof switch "d" – increased safety "e" terminals blocks & cable gland

Housing : standard or polyester "e" FPP type (off-shore application)

According to IP housing, markings, using zones and equipment categories are the following :

EC examination type Examination type	LCIE 02 ATEX 6161X	LCIE 02 ATEX 6161X LCIE 08 ATEX 6057X (voluntary attestation)
Housing protection	IP66 - IP 68	IP56
Marking	CE 0081 Ex II 2GD Exde IIC T6 - Ex tD A21 (or T3 if presence of line resistances)	CE 0081 Ex II 2G/3D Exde IIC T6 - Ex tD A22 (or T3 if presence of line resistances)
for ATEX zones	1 / 2 for gas of groups IIA, IIB, IIC 21 / 22 for dusts	1 / 2 for gas of groups IIA, IIB, IIC 22 for non-conductive dusts
Equipment category	2GD	2G/3D (non-conductive dusts)
Max. surface temperature	80°C (ou 160°C avec résistance de ligne)	

ATEX CERTIFIED INSTRUMENT - EXPLOSIONPROOF (Ex d)

Principle : explosion proof housing "d"

Housing : RTPF type

According to IP 66, markings, using zones and equipment categories are the following :

EC examination type Examination type	LCIE 01 ATEX 6071X	
Housing protection	IP66 - IP 68	
Marking	CE 0081 Ex II 2GD Ex d IIC T6 - Ex tD A21 (with or without line resistances)	
for ATEX zones	1 / 2 for gas of groups IIA, IIB, IIC 21 / 22 for dusts	
Equipment category	2GD	
Max. surface temperature	80°C	

Be careful : use of the cable gland must be conform to the EN 60.079-14 § 10.4 norm (internal volume RTPF < 2 dm³)

Principle : explosion proof switch "d" with output cable

Housing : standard or polyester "e" FPP type (off-shore application)

According to IP housing, markings, using zones and equipment categories are the following :

EC examination type Examination type	LCIE 01 ATEX 6071X	LCIE 01 ATEX 6071X LCIE 08 ATEX 6057X (voluntary attestation)
Housing protection	IP66 - IP 68	IP56
Marking	CE 0081 Ex II 2GD Exd IIC T6 - Ex tD A21	CE 0081 Ex II 2G/3D Exd IIC T6 - Ex tD A22
for ATEX zones	1 / 2 for gas of groups IIA, IIB, IIC 21 / 22 for dusts	1 / 2 for gas of groups IIA, IIB, IIC 22 for non-conductive dusts
Equipment category	2GD	2G/3D (non-conductive dusts)
Max. surface temperature	80°C	

SPECIAL OPTIONS

- submersible housing IP68 (type FPI)
- Oxygen cleaning
- Special cases
- Line resistances
- Navy and nuclear versions
- Scale window on cover

ACCESSORIES

Several accessories could be fitted : diaphragm seals to be screwed or to be welded, with normalized flanges, pressure gauges, temperature gauges, pulsation dampner, cone gauge cocks, 2, 3 or 5 valves manifolds, and so on.

